

- > CENTRAFARI MECCANICO
- > MECHANICAL HEADLIGHT TESTER
- > MECHANISCHES SCHEINWERFEREINSTELLGERÄT

# HBA 19D

DIGITAL LUXMETER

## MECHANICAL

Semi-optical lens in plexiglas  
● diam 200 mm

IT

Centrafari meccanico, con luxometro digitale, visore a specchio, base su ruote, palo con scorrimento con pattini di precisione in nylon autolubrificante, base fissa e pannello regolabile.

EN

**Mechanical headlight beam setter with graduated digital luxmeter, based on wheels, mirror visor. Fixed base and adjustable checking panel.**

DE

Mechanisches Scheinwerfereinstellgerät mit Digitalluxmeter, basiert auf Rädern, Spiegel Visier. Fixierte Platte und regulierbare Platte.

Pannello regolabile 0-4%  
**Adjustable checking panel 0-4%**  
Regulierbares Neigungspanel 0-4%

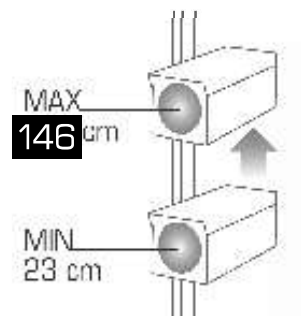

# STANDARD

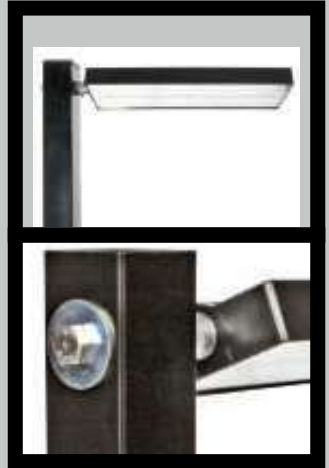

/D

Luxometro digitale  
**Digital Luxmeter**  
Digitalluxmeter



Scorrimento a pinza e scala graduata  
**Sliding system with locking clamp and graduated scale**  
Verschiebung mit Klemmblock und abgestufte Skala



Palo fisso 1660 mm  
**Fixed column 1660 mm**  
Fixierte Säule 1660 mm





/Z

/Z  
Distanziatore/puntatore  
supplementare  
**Spacer/centering bar**  
Zusatzzentrierer



Copertina antipolvere  
**Anti-dust cover**  
Staubschutzhaube

**OPTIONAL**

# HBA 19D Manta

DIGITAL LUXMETER

Pannello regolabile -2+6%  
**Adjustable checking panel -2+6%**  
Regulierbares Neigungspanel -2+6%



Trasporto **Shipping** Fracht

Smontato **Unassembled** Demontiert

1 PC CARTON BOX cm 170x60x45 - Kg. 35  
5 PCS PALLET cm 170x60x175(H) - Kg. 181